

# ROLLING MILLS REVAMP – ROLL UPGRADES FOR EXTREME LOADS

Author: Nicolae Tudor, Specialist Application Engineer – HI Primary Metals, Timken Europe Customer Engineering (Ploiesti, Romania)

## A. Introduction

### Market Overview

Today's rolling mill market environment can be characterized by low investment in new equipment and higher requirements for output. The mills are getting older, but to increase productivity, their operational loads are becoming much heavier. These extreme conditions, along with old and obsolete roll designs, contribute to many of the roll neck failures that occur in 2-HI mill work rolls or 4-HI mill back-up rolls. As a consequence, the market is demanding a rolling mills "revamp" to mitigate roll neck breakage in the fillet ring area under severe loading conditions. The choice of bearing selection can play an important and beneficial role in establishing a successful revamp solution.

### Technical Overview

Rolling mills represent an extremely demanding application for both bearings and rolls, which must perform under high operating temperatures, loads and speeds.

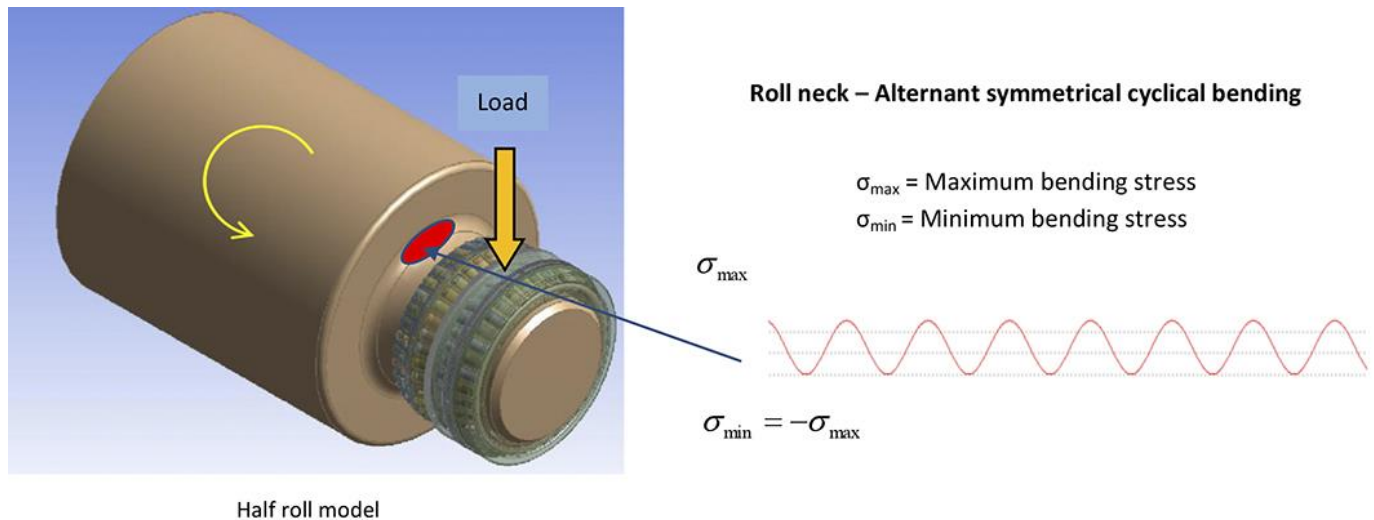

**Figure 1: Roll bending stress**

During the rolling process, the roll rotates and, simultaneously, the load is applied through the bearings on the semi-finished strips. One point on the roll neck supports mainly tensile stress with a maximum value  $\sigma_{\max}$ , while the point found diametrically opposite supports a compressive stress with a minimum value  $\sigma_{\min}$ . When the roll rotates 180°, these two points change position and stress, and the tension progresses from  $\sigma_{\max}$  to  $\sigma_{\min} = -\sigma_{\max}$ . Over time, the material stress on these points varies many times between these two limits (one full variation per rotation), as shown on the graph in Figure 1. As a result, the area of the roll neck between the bearing and the barrel (the fillet radius area) is subjected to alternant symmetrical cyclical bending stress that fluctuates with the roll's rotation. A careful evaluation is required to determine the maximum allowed stress and manage the geometrical features of the transition between the roll neck and barrel diameters (i.e., step chamfers and fillet radii) in order to control the effect of stress concentration.

### The Timken Company solution for revamping heavily loaded roll neck bearings

The Timken Company offers the following roll neck solution engineering support for revamp projects:

- 1) Roll design optimization by maximizing the roll neck diameter
- 2) Design support for a compounded roll neck fillet radius
- 3) Selection of bearings with reduced cross-section (larger bore, same outer diameter\*, same or smaller overall width and special features to maintain or increase bearing load rating)

\*The revamp solution assumes that the same chocks will be used, which requires bearings with the same outer diameter.

## B. Theoretical Considerations of Roll Upgrades for Extreme Loads

### 1. Roll Design Optimization

#### a) Roll neck diameter optimization

In heavily loaded rolls, which often run at slow speeds, a larger neck diameter is needed to cope with the higher bending stress. Based on this need, a conventional heavy-duty bearing size (represented by bearing A in Figure 2) may not be suitable. For these high-load applications, reduced section bearings are suggested (represented by bearing B) with the same outer diameter as the heavy-duty bearings, but with a larger bore. These reduced section bearings offer an increased neck to barrel ratio ( $d/D \sim 68\%$ ) and, whenever possible, a smaller bearing width that also reduces the axial distance between the screw-down load line and the barrel face. The increased roll neck outer diameter and reduced bending moment improve the performance capability of the roll neck under extreme loads.

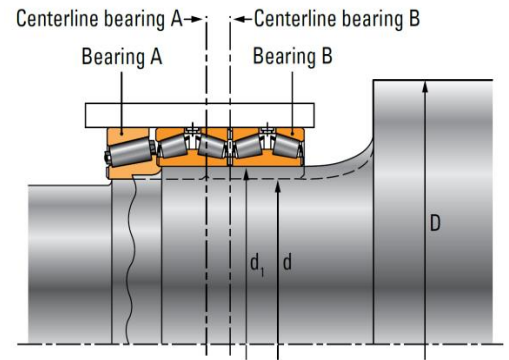

**Figure 2: Roll diameter optimization**

#### b) Replace existing fillet radius with a compound fillet radius

Traditional roll neck designs often use a simple radius in the fillet area. Timken's long experience in the steel-making industry indicates that this solution may be inappropriate for heavily loaded mills, and recommends replacing the simple radius with a compound fillet radius. Compound – or two-radii – fillets are recommended because they offer favorable stress distribution across the fillet radius. Figure 3 shows the development of the compound radii fillet from two predetermined fillet length and height dimensions  $r_a$  and  $r_b$ , respectively, with the purpose of reducing roll neck maximum stress. The length and height of the fillet radii  $r_c$  and  $r_d$  can be determined using the following formulas:

$$r_c = r_a + \frac{(r_a - r_b)^2}{2(r_b - r_d)} \quad r_d = \frac{4r_b - r_a}{3}$$

$r_a$  = Fillet length ( $r_a$  is less than  $2.5 r_b$  for practical purposes)

$r_b$  = Fillet height

$r_c$  = Major radius of compound fillet

$r_d$  = Minor radius of compound fillet

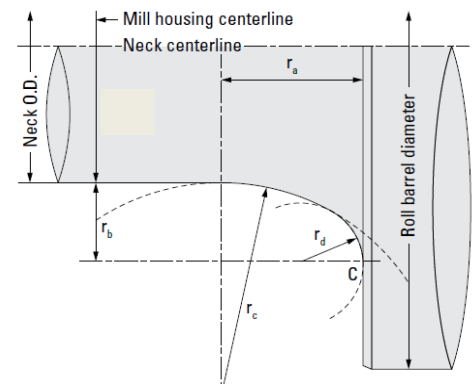

**Figure 3: Compound fillet radius**

### 2) Bearings with Reduced Cross-Section

Timken engineers use sophisticated, application-focused computer programs to model applications and operating environments, producing specially designed bearings that yield longer life. To maximize bearing performance in tough operating conditions, Timken has developed the DuraSpexx® Power Rating Series of bearings. DuraSpexx® bearings feature a modified design that offers enhancements to improve bearing life in demanding applications with harsh environments. DuraSpexx® bearings are ideal for heavy-load industrial applications such as rolling mills and gear drives. The enhanced features and reduction in cross-section of these bearings result in higher bearing ratings. DuraSpexx® leverages Timken technical design knowledge to achieve a 23% bearing dynamic rating increase, resulting in fatigue life increase versus the standard Timken bearing, as shown in Figure 4.

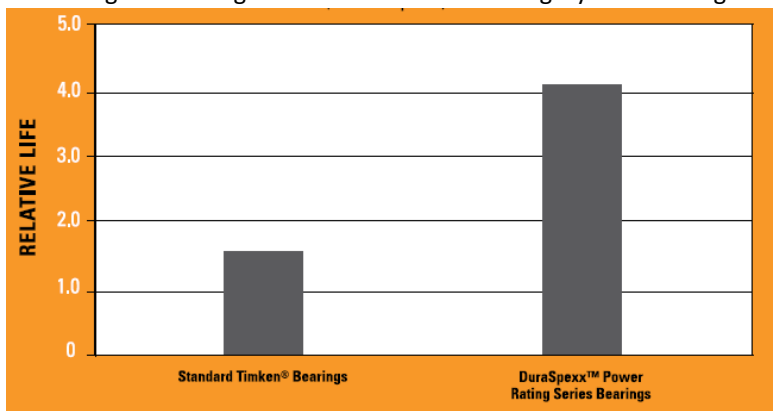

**Figure 4:**  
**Comparative life results for the DuraSpexx® Power Rating Series vs. standard Timken bearings within the same envelope**

### DuraSpexx® Design Attributes

- Enhanced steel materials with improved cleanliness and modified inclusion shape to reduce inclusion-related damage
- Surface finishing options to reduce peeling and fatigue in high-temperature and thin lubricant film environments
- Profiled geometry to optimize contact stress distribution under high loads and/or misalignment

### C. Case Study – Existing Solution and Problem Description

This application is performed on rolls of 2-HI mills, but could be extended to the back-up rolls of 4-HI mills. Figure 5 shows the roll load and current fillet radius detail.

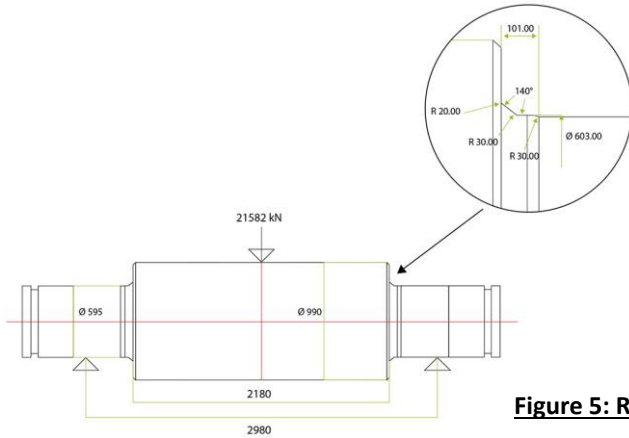

**Figure 5: Roll load and fillet radius detail**

### Mill design attributes

Mill type: 2-HI mill

Roll barrel diameter: 990 mm

Barrel width: 2180 mm

Roll neck diameter: 595 mm

Roll neck to barrel ratio: 60%

Screw-down distance: 2980 mm

Roll body material: Steel

Young's modulus: 210000 MPa

Poisson's ratio: 0.3

Tensile yield strength: 250 MPa

Tensile ultimate strength: 460 MPa

The isometric view of the roll is shown in Figure 6.

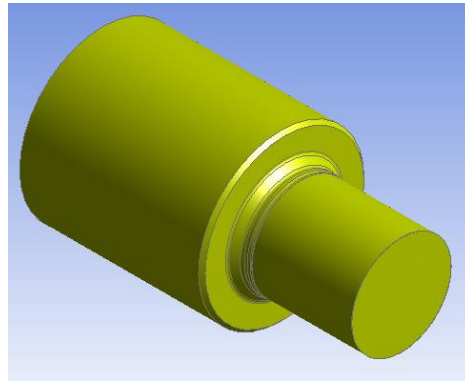

**Figure 6: Roll neck fillet design:  
Isometric view**

### Operating conditions

Max. rolling load: 2200 tons (= 21582 kN)

Max. rolling speed: 220 m/min at pass line

### Timken bearing

Figure 7 shows an expanded view of the four-row tapered bearing made up of two double inner rings, four single outer rings, one inner ring spacer and three outer ring spacers.

Bearing: 4-row TRB M280049DW-M280010

Envelope: 595.312 x 844.550 x 615.950 (ID x OD x width in mm)

Timken rating: C90(4) = 4400 kN

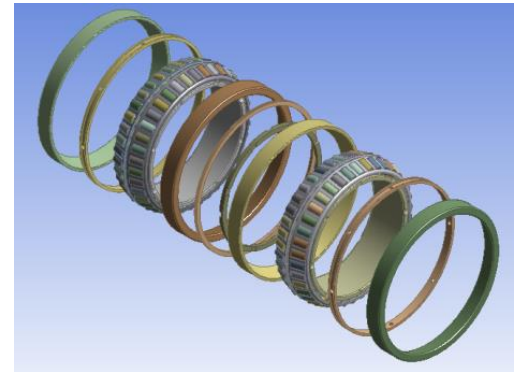

**Figure 7: Expanded view of  
the 4-row tapered bearing**

### Computer model

Figure 8 shows the isometric view of the computer model. The computer-modeled application is shown in Figure 9.

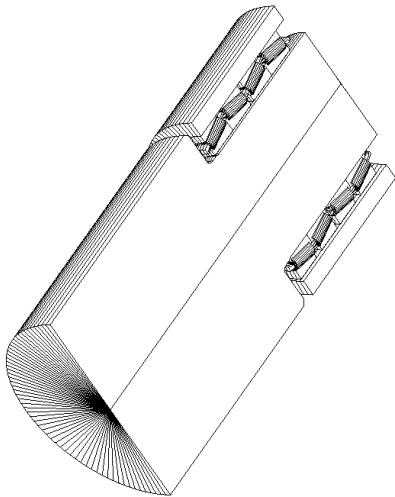

**Figure 8: Computer model:  
Isometric view**

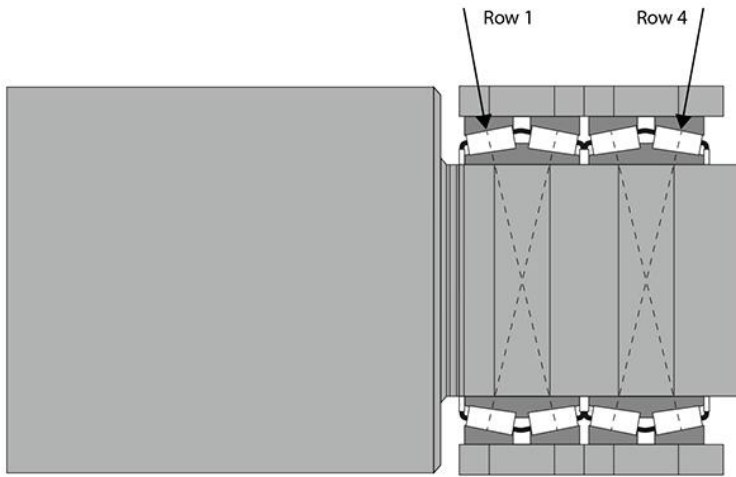

**Figure 9: Computer model**

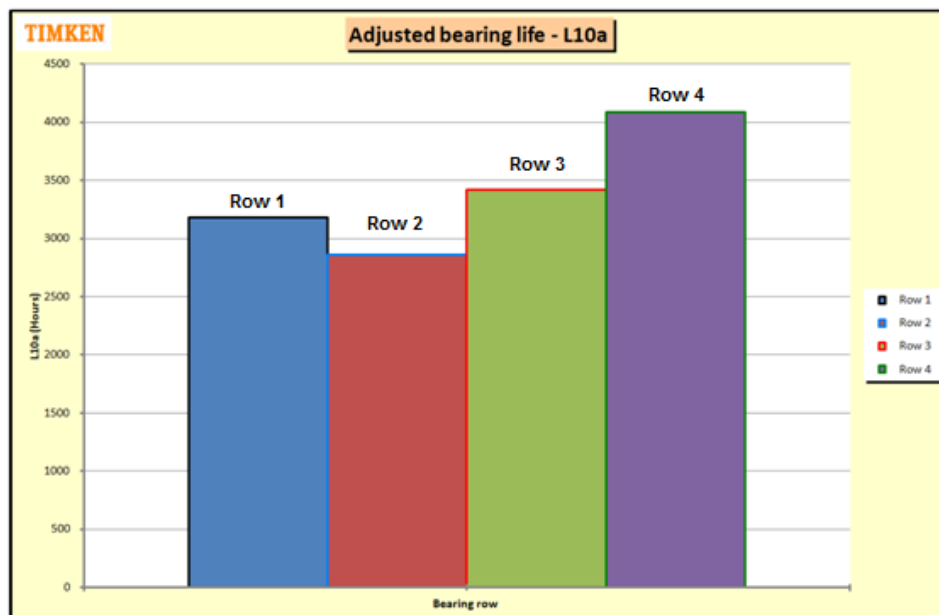

**Figure 10: Adjusted bearing life**

The adjusted bearing fatigue life L10a of the maximum loaded row, presented in Figure 10, is 2800 hours.

Since the bearing cups are stationary in the chocks, only one part of the cup carries the rolling load at any given time. This part is called the 'load zone'. Roll neck bearing cups are marked on their back and front faces to show four quadrants. The cup face markings enable the user to keep a record of which quadrants have been used in the load zone.

A good practice is to mount the bearing with quadrant number 1 of each cup in the load zone, then during subsequent inspections rotate to each of the others, in sequence, until the procedure repeats again with number 1. The rotation of the cups at every inspection will extend the useful life of the bearing by incrementally distributing the load over the entire cup raceway.

The roll maximum stress on the fillet area of 352 N/mm<sup>2</sup> and the roll fatigue life of 4400 hours are presented in Figure 11.

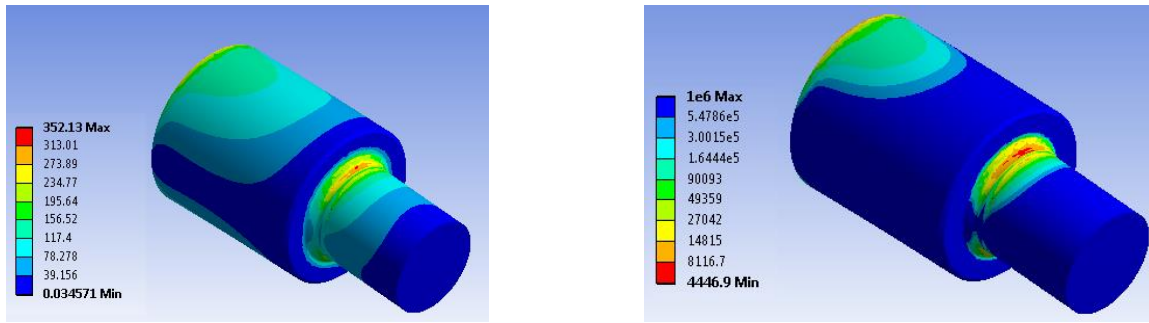

**Figure 11: Roll neck assessment before upgrade: Maximum stress and fatigue life**

**Problem description – Roll neck breakage**

The roll was broken at its fillet radius area, as shown in Figure 12. The customer requested Timken Support for solutions to increase roll neck strength and keep the new bearing fatigue life within acceptable limits. There were no reported issues with the existing bearing selection.



**Figure 12: Roll neck breakage**

**D. Case Study – Timken Roll Upgrade Solution**

Timken suggested roll design optimization by increasing the neck diameter from Ø595 to Ø610 mm and replacing the existing fillet radius with a compound fillet. The bearing external diameter and width were maintained at their initial values. Note that the mill chock covers and seals had to be replaced due to the larger bearing bore.

**1) Increase Roll Neck Diameter (from 595 to 610 mm)**

**Mill design attributes**

- Roll barrel diameter: 990 mm
- Barrel width: 2240 mm
- Roll neck diameter: 610 mm
- Roll neck to barrel ratio: 62%

**New Timken bearing**

- Bearing: 4-row TRB NP825343-NP205014 (shown in Figure 13)
- Envelope: 610.000x844.550x615.950 [ID x OD x Width in mm]
- Timken rating: C90(4) = 5020 kN with standard Timken bearing
- Timken rating: C90(4) = 6175 kN with DuraSpexx® bearing design

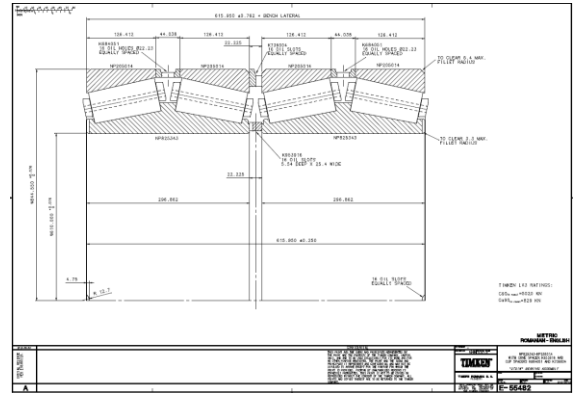

**Figure 13: Bearing schematic**

**2) Replace Existing Fillet Radius with Compound Fillet Radius**

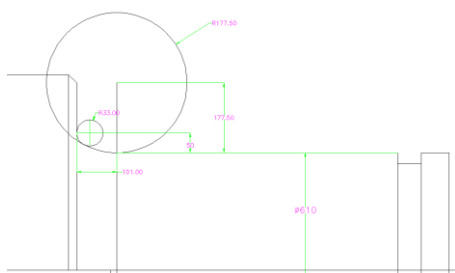

**Inputs**

- $r_a = 101 \text{ mm}$
- $r_b = 50 \text{ mm}$

**Outputs**

- $r_c = 177.5 \text{ mm}$
- $r_d = 33 \text{ mm}$

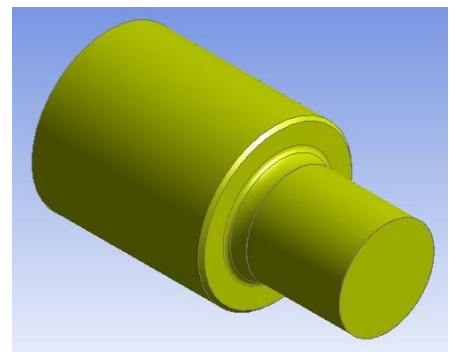

**Figure 14: Optimized roll neck fillet**

The adjusted bearing fatigue life L10a, shown in Figure 15, is 4500 hours for the standard Timken bearing and 9000 hours for the DuraSpexx® bearing design.

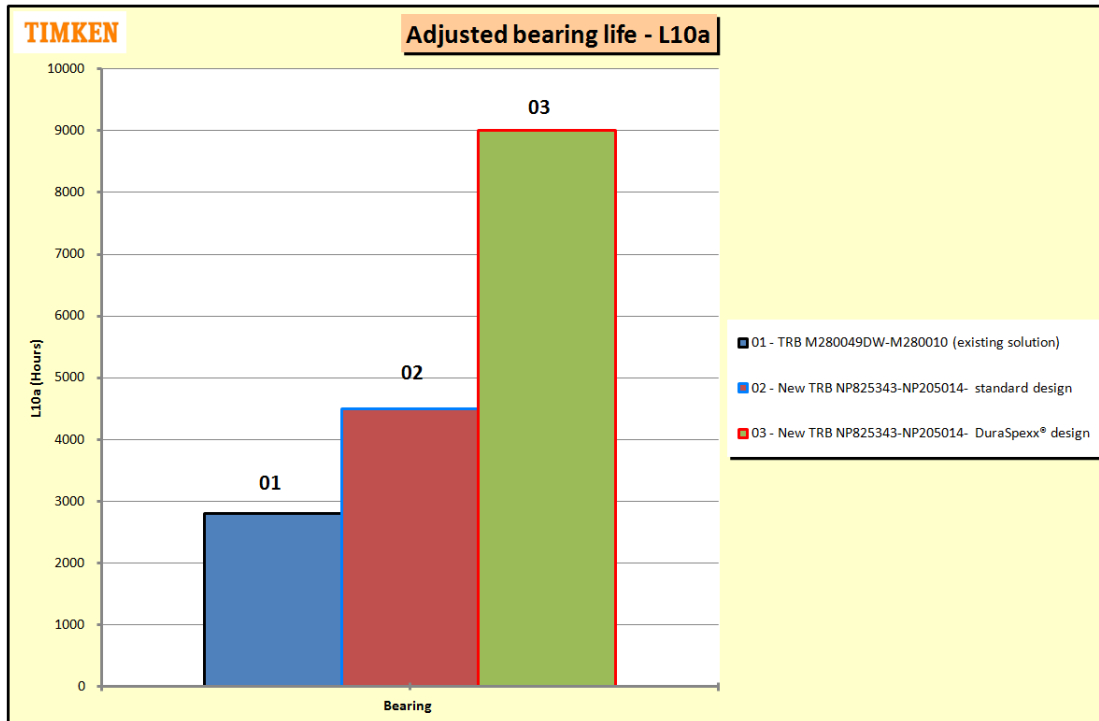

**Figure 15: Adjusted bearing life L10 for existing solution vs. standard and DuraSpexx® bearing designs**

The maximum roll stress on the fillet area of  $318 \text{ N/mm}^2$  and the roll fatigue life of 6000 hours are shown in Figure 16.

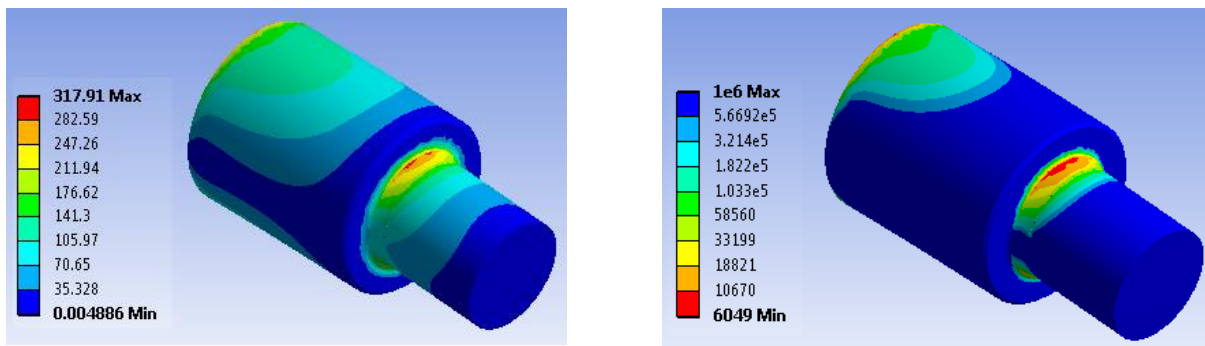

**Figure 16. Roll neck assessment after upgrade: Maximum stress and fatigue life**

#### Results of roll upgrade

1. Decreased the maximum roll stress from  $352 \text{ N/mm}^2$  to  $318 \text{ N/mm}^2$ , a decrease of 9.6%.
2. Increased the roll fatigue life from 4400 hours to 6000 hours, an increase of 36%.
3. Increased bearing fatigue life L10a of the standard Timken bearing from 2800 hours to 4500 hours, an increase of 60%.
4. Increased bearing fatigue life L10a of the new DuraSpexx® bearing from 2800 hours to 9000 hours, an increase of 120%.

#### E. Summary and Conclusions

The market is now requesting roll mill revamps because of the frequent failures caused by roll neck breakage in the fillet ring area. The Timken Company has extensive expertise in this area, and offers both engineering support for roll design optimization and bearings with a reduced cross-section. These measures improve roll performance by decreasing the maximum roll stress and increasing roll and bearing fatigue life.

#### Acknowledgements

The authors would like to thank The Timken Company for permission to publish this study.

## References

1. Harris, T. and Kotzalas, M. (2007), "Rolling Bearing Analysis – Advanced Concepts of Bearing Technology"
2. Association of Iron and Steel Engineers (1985), "The Making, Shaping and Treating of Steel," 10<sup>th</sup> Edition
3. The Metals Society (1978), "Flat Rolling: A Comparison of Rolling Mill Types"
4. ISO 281 (2007), Rolling Bearings – Dynamic Load Ratings and Rating Life
5. Timken Engineering Manual – Metals Industry Edition
6. Timken Metals Product Catalog

For more information on the DuraSpexx® Bearing Series, visit:

<http://www.timken.com/en-us/products/bearings/productlist/HighPerformance/Pages/DuraSpexx.aspx>

or contact your local Timken sales representative.